

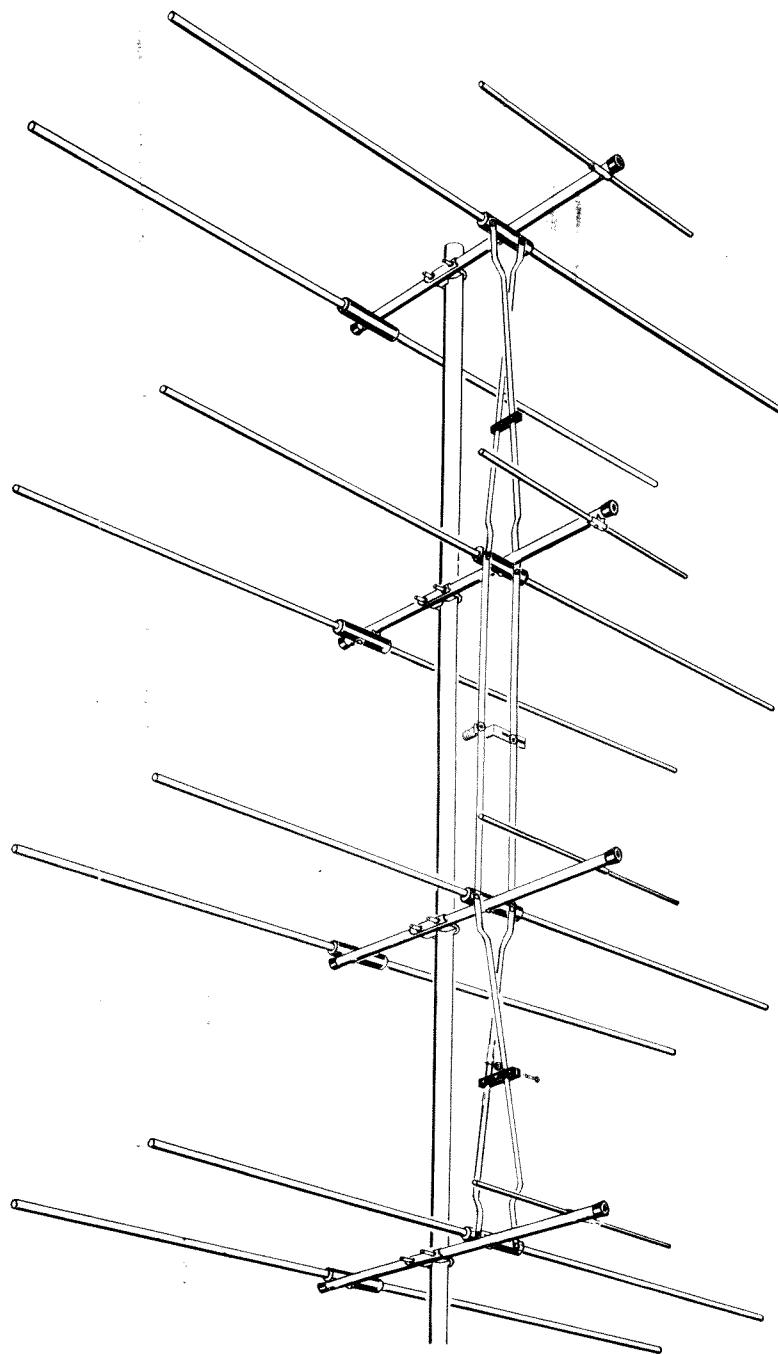

ASSEMBLY INSTRUCTIONS



20 ELEMENT DX-ARRAYS

DX-120 DX-220 DX-420

PARTS LIST	DESCRIPTION	QUANTITY
BOOMS:	3/4" O.D. aluminum tubing -----	4
REFLECTORS:	1/4" Solid rod with insulators -----	4
DIPOLES:	1/4" Solid rod with insulators and double hex nuts -----	4
DIRECTORS:	3/16" Solid rod -----	4
END STACKING BARS:	Solid, formed aluminum rod -----	4
CENTER STACKING BARS:	2 Solid, straight aluminum rods -----	1
COAXIAL FITTING ASSEMBLY	-----	1

PART NO.	PARTS PACKAGE DESCRIPTION	QUANTITY		
		DX-120	DX-220	DX-420
3	1 1/2" U-bolts -----	4	4	4
4	1 1/2" U-bolt brackets -----	4	4	4
8	1/4" O.D. Flat aluminum washers -----	1	1	1
9	8 -32 x 5/8" stainless steel bolts -----	8	-	-
10	#8 Internal tooth lock washers -----	3	3	3
11	8 - 32 Hex stainless steel nuts -----	19	3	3
12	3/4" Plastic caps -----	8	8	8
14	1 1/2" U-bolt backing plates -----	4	4	4
16	1/4" Lock washers -----	8	8	8
17	1/4" Hex nuts -----	8	8	8
21	10 - 24 x 2" bolts -----	12	12	12
22	10 - 24 Hex nuts -----	12	12	12
25	7/8" Formed aluminum brackets -----	12	12	12
26	8 - 32 x 1" stainless steel bolts -----	3	1	1
28	Aluminum half washers -----	4	4	4
29	#10 Internal tooth lock washers -----	12	12	12
30	Black phenolic spacers -----	2	-	-

INSTALLATION SUGGESTIONS

Your Cush Craft 20 element DX-Array is designed and manufactured to give top performance and trouble free service. The antenna will perform as specified if the instruction and suggestions are followed and if care is used in assembly and installation. When properly assembled and aligned the DX-Array is an inconspicuous VHF/UHF antenna system.

MASTING: The mast mounting brackets will take up to a 1 1/2" O.D. mast. A 1 1/4" O.D. television type tubing is satisfactory for the 20 element array.

MOUNTING: When mounting DX-Arrays on the same mast with other (dissimilar) antennas they may be mounted within 3' of the other antenna. Generally, it is best to mount the DX-Arrays above lower frequency antennas. The DX-220 and DX-420 arrays may be mounted back to back on the same mast.

ROTATOR: A good quality television antenna rotator will easily handle the 20 element DX-Arrays. Any larger antennas mounted on the same mast or conversion to the 40 element DX-Array will require a heavy duty amateur type rotator.

LOCATION: of the antenna is extremely important. Surrounding objects such as trees, power lines, other antennas, etc. will seriously reduce efficiency. To minimize the effects of surrounding objects mount the antenna as high and in the clear as possible. If metal guy wires are used they should be broken with strain insulators installed approximately 4' from the top.

FEED SYSTEM: The 20 element DX-Arrays incorporate a unique coaxial feed system. The arrays are balanced antennas connected to an unbalanced cable at the feed point. Equal voltage distribution is accomplished through the stacking bars to the upper and lower bays. The use of a coupler or other type matching device is not recommended.

A 1-1 balun is available for the 20 element DX-Arrays. When installed between the antenna and feed cable it will eliminate any stray RF from the feed cable. If the 1-1 balun is used it should be connected to the antenna, figure 4, before tuning.

TUNING: The DX-Arrays may be tuned at ground level by mounting them on a non conductive support such as a wooden box saw horse, etc. Lay out the assembled array with the reflector elements parallel to and approximately 2' above the ground. This will effectively isolate the array from ground so that there will be little or no change in the VSWR when it is raised into position on your mast or tower.

- (1) When tuning the DX-Arrays (or any VHF/UHF antenna) a good quality VSWR bridge must be used. The bridge should be connected at the antenna fitting or as close to it as possible. Any cable between the bridge and the antenna should be a half wave length or multiples of a half wave length long. This procedure also applies if the 1-1 balun is used. The half wave length should be measured from the input of the 1-1 balun.
- (2) Set the transmitter or signal source to your operating frequency.
- (3) Adjust the bridge for maximum forward power. Check the standing wave ratio with the bridge in the reverse position. If the VSWR is high loosen the stacking bar connection on the slotted side of the coaxial terminal assembly. Compress or expand this stacking bar slightly to change the spacing between the bars. Move away from the antenna and check the reading. If the VSWR has increased move the stacking bar back to its original position and adjust in the opposite direction. If the VSWR dropped repeat the adjustment procedure until there is little or no reflected power indicated on the bridge.
- (4) When the antenna is completely assembled and tuned tighten all fasteners securely. The coaxial cable from your transmitter may be any random length. However, it should be as short as possible to keep feed line losses at a minimum. Run the feed cable straight back to the vertical support mast and down, with tape to hold it in position. If the 1-1 balun is used run it at a 45° angle from the fitting down to your vertical support mast. All fasteners and connections should be spray coated with a clear acrylic spray, or equal.

LIGHTNING PROTECTION: Grounding the base of your mast or tower will provide only a limited amount of protection, because the center conductor of your coaxial cable still provides a direct path to your equipment. The Blitz Bug coaxial cable lightning arrester provides a static drain point for the cable and entire system. Blitz Bug gives full time lightning protection, and in many cases eliminates static noise conditions. Blitz Bug will handle 1 KW AM, fully modulated. It will not upset the performance of your equipment, or increase the standing wave ratio on the line. **THERE IS NO BETTER INSURANCE THAN A GENUINE BLITZ BUG THE ONLY USER PROVEN COAXIAL CABLE LIGHTNING ARRESTER!**

ELEMENT ASSEMBLY: The DX-120 elements are shipped in two sections which are taped together. To assemble these elements insert the drilled end of the element rod into the center insulator. You will notice a small ridge on one side of the drilled rod. The head of the 1" bolt should be placed against this ridge. Tighten the element to the insulator using an 8 - 32 nut as shown in figure 2. The DX-220 and DX-420 elements are factory pre-assembled.

ELEMENT MOUNTING: On the DX-120 the mast mounts between the reflector and dipole elements. On the DX-220 and DX-420 the mast mounts behind the reflector. Assemble the four bays by mounting the elements on the booms as shown in figure 2. The bolts on the dipoles should point toward the director elements, as illustrated. Assemble the U-bolts and mounting brackets on the same side of all booms, figures 1 & 2.

BOOM MOUNTING: When mounting the booms on your support mast (figure 1) the insulators on the two top bays should be below the booms. On the two lower bays the insulators should be on top of the booms. Mount the booms on your vertical support mast keeping all booms in line on the same side of the mast. Tighten the u-bolt on the top bay securely. The 3 lower bays should only be finger tight at this stage. Spacing between the bays is determined by the length of the stacking bars.

STACKING BARS: Assemble the two straight center stacking bars to the coax fitting as illustrated in figure 3. Place the stacking bars on the dipole terminals, figures 1 & 2, tighten finger tight. Be sure that the end stacking bars are crossed and do not touch each other. When assembling two 20 element antennas for the 40 element array be sure that the crossed stacking bars of the second antenna exactly duplicate the first antenna. On the DX-120 use the spacer insulator to maintain the proper space between bars, figure 1. Mount the center stacking bar assembly between the two center bays with the coax fitting on the support mast side. The center stacking bars do not cross.

ALIGNMENT: Sighting from the top boom as a guide, align the remaining booms and tighten all u-bolts securely. When the booms are all aligned and tightened, tighten all stacking bar connections.

VERTICAL POLARIZATION: To use the DX-Array for vertical polarization assemble and mount the antenna on a support mast as outlined above. Minimum lengths for this mast are given in Chart A. Attach a mast mount bracket (Cush Craft DX-VPB) at the center of this mast, figure 5, which now becomes the horizontal support. Attach your vertical support mast to this bracket and mount the antenna with the elements in the vertical position. Feed line connections and tuning procedures are the same as for the horizontally polarized antenna.

OPERATION: The DX-120 is cut at 145.8 mhz. It will cover the entire 2 meter band with a VSWR of less than 1.8-1, and the lower end with a VSWR of less than 1.5-1. The DX-120 may be cut for FM repeater or other use at the high end of the band. For operation in the 146-148 mhz range cut 1/2" from each end of the dipole and reflector elements. Cut 1/4" from each end of the directors.

The DX-220 is cut at 221.0 mhz and will cover the entire band with a VSWR of 1.5-1 or less.

The DX-420 is cut at 432 mhz and will cover the most popular portion of the band with a VSWR of less than 1.5-1. For operation at the high end 448.0 mhz cut 1/4" from each end of all elements, including the directors.

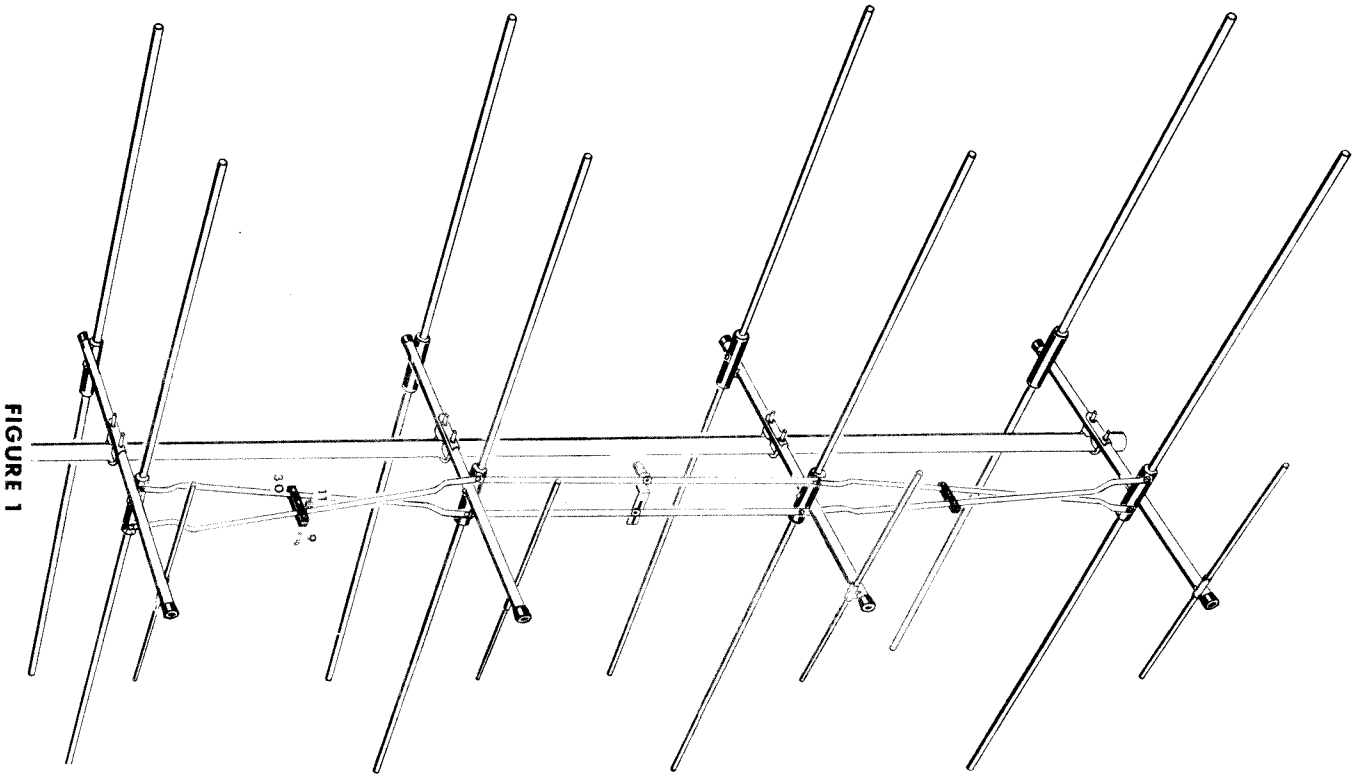

FIGURE 1

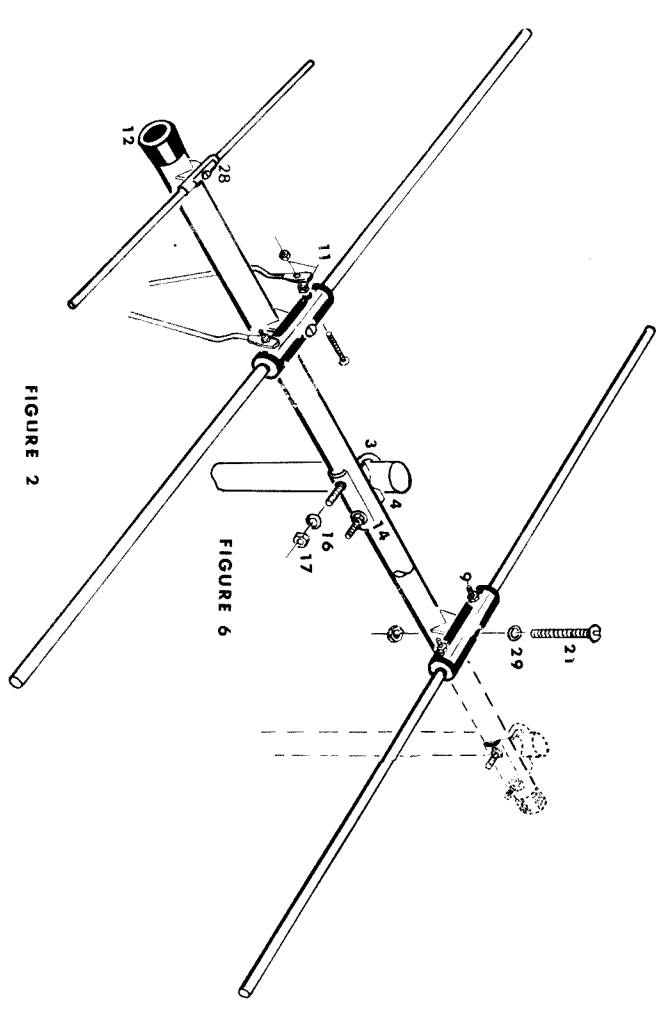

FIGURE 2

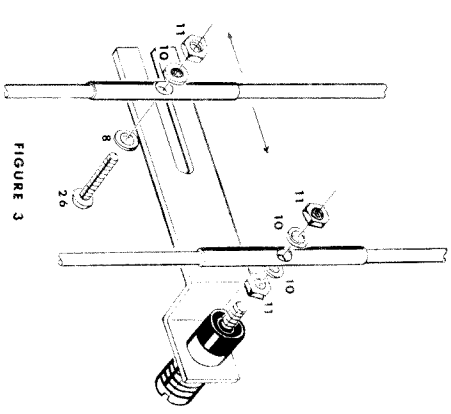

FIGURE 3

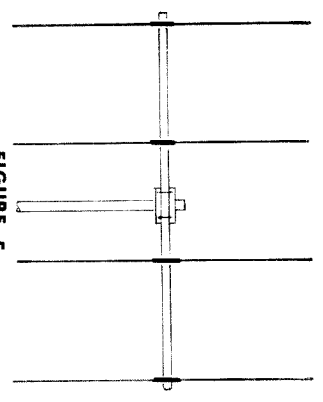

FIGURE 5

CHART A

DX-120	--	120"
DX-220	--	80"
DX-420	--	44"

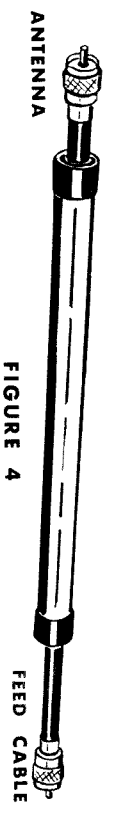

FIGURE 4

WARNING

THIS ANTENNA IS AN ELECTRICAL CONDUCTOR. CONTACT WITH POWER LINES CAN RESULT IN DEATH, OR SERIOUS INJURY.

DO NOT INSTALL THIS ANTENNA WHERE THERE IS ANY POSSIBILITY OF CONTACT WITH OR HIGH VOLTAGE ARC-OVER FROM POWER CABLES OR SERVICE DROPS TO BUILDINGS.

THE ANTENNA, SUPPORTING MAST AND/OR TOWER MUST NOT BE CLOSE TO ANY POWER LINES DURING INSTALLATION- REMOVAL OR IN THE EVENT PART OF THE SYSTEM SHOULD ACCIDENTALLY FALL.

CONSULT THE NATIONAL ELECTRICAL CODE FOR FURTHER DETAILS.

" LIMITED WARRANTY "

CUSHCRAFT CORPORATION, P. O. BOX 4680, MANCHESTER, NEW HAMPSHIRE 03108 WARRANTS TO THE ORIGINAL CONSUMER PURCHASER FOR ONE YEAR FROM DATE OF PURCHASE THAT EACH CUSHCRAFT ANTENNA IS FREE OF DEFECTS IN MATERIAL OR WORKMANSHIP. IF, IN THE JUDGMENT OF CUSHCRAFT, ANY SUCH ANTENNA IS DEFECTIVE, THEN CUSHCRAFT CORPORATION WILL, AT ITS OPTION, REPAIR OR REPLACE THE ANTENNA AT ITS EXPENSE WITHIN THIRTY DAYS OF THE DATE THE ANTENNA IS RETURNED (AT PURCHASER'S EXPENSE) TO CUSHCRAFT OR ONE OF ITS AUTHORIZED REPRESENTATIVES. THIS WARRANTY IS IN LIEU OF ALL OTHER EXPRESSED WARRANTIES. ANY IMPLIED WARRANTY IS LIMITED IN DURATION TO ONE YEAR. CUSHCRAFT CORPORATION SHALL NOT BE LIABLE FOR ANY INCIDENTAL OR CONSEQUENTIAL DAMAGES WHICH MAY RESULT FROM A DEFECT. SOME STATES DO NOT ALLOW LIMITATIONS ON HOW LONG AN IMPLIED WARRANTY LASTS OR EXCLUSIONS OR LIMITATIONS OF INCIDENTAL OR CONSEQUENTIAL DAMAGES, SO THE ABOVE LIMITATION AND EXCLUSION MAY NOT APPLY TO YOU. THIS WARRANTY GIVES YOU SPECIFIC LEGAL RIGHTS, AND YOU MAY ALSO HAVE OTHER RIGHTS WHICH VARY FROM STATE TO STATE. THIS WARRANTY DOES NOT EXTEND TO ANY PRODUCTS WHICH HAVE BEEN SUBJECT TO MISUSE, NEGLIGENCE, ACCIDENT OR IMPROPER INSTALLATION. ANY REPAIRS OR ALTERATIONS OUTSIDE OF THE CUSHCRAFT FACTORY WILL NULIFY THIS WARRANTY.



P.O. BOX 4680, MANCHESTER, N.H. 03108

SPECIFICATIONS SUBJECT TO CHANGE WITHOUT NOTICE

K4XL's **BAMA**

This manual is provided **FREE OF CHARGE** from the “BoatAnchor Manual Archive” as a service to the Boatanchor community.

It was uploaded by someone who wanted to help you repair and maintain your equipment.

If you paid anyone other than BAMA for this manual, you paid someone who is making a profit from the free labor of others without asking their permission.

You may pass on copies of this manual to anyone who needs it. But do it without charge.

Thousands of files are available without charge from BAMA. Visit us at <http://bama.sbc.edu>